



NEW BUSINESS



STAFF REPORT

To: SBWMA Board Members
From: Kevin McCarthy, Executive Director
Marshall Moran, Finance Manager
Date: November 18, 2010 Board of Director's Meeting
Subject: Resolution Approving Shoreway Facility Tipping Fee Adjustments Effective 1/1/11

Recommendation

It is recommended that the SBWMA Board of Directors approve Resolution No. 2010-34 attached hereto authorizing the following action:

Approval of the following Shoreway facility tipping fee adjustments effective January 1, 2011:

- Increase SBWMA (franchised) solid waste disposal rates by \$9.00/ton from \$84.00/ton to \$93.00/ton
- Increase SBWMA (franchised) plant material recycling rates by \$9.00/ton from \$70.00/ton to \$79.00/ton
- Increase public weighed rates for C&D materials (dirt, concrete, asphalt, rock, etc.) by \$5.00/ton from \$83.00/ton to \$88.00/ton
- Increase public (residential, commercial) disposal rates by \$5.00/cubic yard from \$35.00/cubic yard to \$40.00/cubic yard
- Increase public (residential, commercial) clean plant material and wood recycling rates by \$4.00/cubic yard from \$25.00/cubic yard to \$29.00/cubic yard
- No change in the cubic yardage rate of \$28.00 for clean construction and demolition.

These recommended tipping fees are the same as proposed in the approved FY 10/11 budget and in the bond proforma assumptions.

Analysis

When evaluating potential adjustments to the Shoreway tipping fees, staff took into consideration three key factors:

- Cash flow requirements assumed for the Shoreway bond financing to pay for the masterplan improvements.
- The cumulative revenue surplus/deficit at the end of 2010 in terms of compensation paid to Allied to operate the Shoreway facility.
- An analysis of tip fees collected per ton versus actual operating costs per ton by material type (solid waste, plant materials, food scraps and C&D).

As part of the analysis we also completed our annual survey of tipping fees at select Bay area transfer stations and landfills and have included the results as **Attachment A**.

Shoreway Bond Financing

Future proposed tipping fee adjustments were a key consideration in achieving sufficient cash flow requirements and ultimately prudent debt coverage ratios. The Agency's ability to approve these projected tipping fees was a key consideration by the rating analysts when reviewing our credit rating. Some key comments from the rating analysts are noted below.

S&P August 13, 2009 Rating Report (reaffirmed A- with stable outlook)

"The board adopted rate increases for calendar 2009, and the authority has indicated that the Board is aware of the necessity of the rate increases to meet future debt service coverage."

"The rating reflects our belief that there may be some fluctuation in year-over-year revenue performance and dependence on rate increases in order to generate sufficient operating revenue to support debt service by fiscal 2012. The stability of the rating will depend on the authority's ability to achieve satisfactory coverage of annual debt service by system net revenue, without a recurring reliance on a rate stabilization fund or other reserves."

Moody's August 13, 2009 Rating Report (downgrade TO A3 FROM A2)

"The SBWMA has taken some key steps to remedy the deterioration of its finances. Subsequently Moody's expects the SBWMA's fiscal position to return to a level of stability in fiscal 2010. However, it appears that this stability will be at a lower level of fiscal soundness than in previous years. The SBWMA's board has approved significant future tipping fee increases. These increases are expected to be 12.5%, 11.1% and 5.5% in years 2010, 2011, and 2012 respectively. After this period, the enterprise will adjust rates by an annual CPI adjustment. However, Moody's notes that only the increase for fiscal 2010 is currently in place with the additional increases requiring a vote of the board before being implemented. Though the board has agreed in principle to the future increases, the new tipping fee rates are not yet in place and could be amended."

SBWMA Revenue Requirement

Based on a review of the final rate review documents from HF&H staff is not recommending a change in the proposed 2011 tipping fee adjustments to cover any Allied Shoreway operating deficits (cumulative rate years 2009-2010). The projected operating deficits are in effect the SBWMA's balancing account with Allied and the deficits are somewhat worse than originally projected in our operating budgets. Our current bond proforma projections, see agenda item 6C, assume pay-off of the 2009 Allied balancing account in full in 2011 and pay-off of one quarter (three months) of the projected 2010 deficit in 2011. Staff will bring back a separate item as part of the mid-year budget review for Board approval of a repayment schedule for the Allied balancing account.

If we look at the recommended 2011 tipping fee revenues and projected transfer station operational costs (see **Attachment B**), the franchised solid waste rate does cover projected operational costs. The franchised green waste rate is below our projected operational costs. The projected operational costs below are assumptions taken from the Board approved 2011 South Bay Recycling Compensation Application.

2011 projected rates:

	(Revenue)	(Expense)
<u>Material</u>	<u>Tipping Fee</u>	<u>Operational Costs (Shoreway + disposal/processing rates)</u>
Solid Waste	\$93.00/ton	\$44.68 (see detail in Attachment B) + \$37.74 (Ox Mtn. rate) = \$82.42
Residential Organics	\$79.00/ton	\$53.10 (see detail in Attachment B) + \$36.25 (blended rate of Newby and Grover tip fees) = \$89.35/ton
Commercial Organics	\$79.00/ton	\$50.31 (see detail in Attachment B) + \$55.00 (Newby rate) = \$105.31/ton

NOTE: The residential and commercial organics figures above are for franchised tons. The blended cost per ton for all organics tons, assuming 82% of tons are residential and 18% is commercial, equals \$92.22.

C&D	\$88.00/ton	\$47.34 (see detail in Attachment B) + \$45.81 (Zanker Road) = \$83.79/ton
-----	---	--

In terms of yardage rates, our current rates for solid waste and plant materials (assuming a 4:1 or 5:1 cubic yards/ton conversion) generate more than sufficient revenue to cover operating expenses. The C&D yardage rate (assuming a 3.18 cubic yards/ton conversion, 3.18 x \$28/cu. yd. equals \$89.04) does cover operating expenses.

Comparison to Other Transfer Station and Landfill Rates

Limited consideration was also given to a comparison of Shoreway gate rates with those at other publicly and privately owned transfer stations and landfills in the Bay area. This rate comparison can be found in **Attachment A**. SBWMA franchised disposal rates still remain competitive compared to other solid waste facilities. Our public C&D cubic yardage rate is also very competitive.

Background

Historical tipping fees at the Shoreway facility are summarized below.

Year:	2005	2006	2007	2008	2009	1/1/10	7/1/10
<u>Rates</u>							
Franchised Solid Waste	\$67.50/ton	\$59.00/ton	\$61.00/ton	\$63.00/ton	\$72.00/ton	\$81.00/ton	\$84.00/ton
Franchised Plant Materials/Organics	--	\$48.50/ton	\$48.50/ton	\$52.50/ton	\$60.50/ton	\$69.50/ton	\$70.00/ton
Public Solid Waste	\$20.00/yard	\$20.00/yard	\$22.00/yard	\$25.00/yard	\$29.00/yard	\$34.00/yard	\$35.00/yard
C&D		\$20.00/yard	\$22.00/yard	\$25.00/yard	\$29.00/yard	\$34.00/yard	\$28.00/yard
Public Green Waste	\$16.50/yard	\$16.50/yard	\$16.50/yard	\$19.00/yard	\$22.00/yard	\$25.00/yard	\$25.00/yard

These tipping fees were last adjusted effective July 1, 2010 to address County disposal fee increase of \$2.81 per ton. The County Board of Supervisors voted on December 1, 2009 to increase their AB 939 fee from \$7.02 per ton to \$9.83 per ton effective July 1, 2010.

Fiscal Impact

As noted in the Allied Waste 2010 collection rate report, proposed tipping fee increases will increase collection rates by 3%.

Attachments:

Resolution 2010-34

A - Comparison of Bay Area Transfer Station and Landfill Rates

B - Operating Expense Detail



RESOLUTION NO. 2010-34

RESOLUTION OF THE SOUTH BAYSIDE WASTE MANAGEMENT AUTHORITY BOARD OF DIRECTORS

WHEREAS, staff has submitted a report to the Board, dated November 11, 2010 recommending adjustments to the tipping fees charged at the Shoreway Recycling and Disposal Center (the Tipping Fees); and

WHEREAS, the SBWMA Board has reviewed the suggested changes to the Tipping Fees.

NOW, THEREFORE, BE IT RESOLVED that the SBWMA Board approves the adjustments to the Tipping Fees as recommended in the staff report.

PASSED AND ADOPTED by the Board of Directors of the South Bayside Waste Management Authority, County of San Mateo, State of California on the this 18th day of November, 2010, by the following vote:

Agency	Yes	No	Abstain	Absent	Agency	Yes	No	Abstain	Absent
Atherton					Menlo Park				
Belmont					Redwood City				
Burlingame					San Carlos				
East Palo Alto					San Mateo				
Foster City					County of San Mateo				
Hillsborough					West Bay Sanitary Dist				

I HEREBY CERTIFY that the foregoing Resolution No. 2010-34 was duly and regularly adopted at a regular meeting of the South Bayside Waste Management Authority on November 18, 2010.

ATTEST:

Jim Porter, Chairperson of SBWMA

Jeannene Minnix Kingston, Board Secretary

Facility	City	Public	Private	Permitted TPD	HH Trash		Comm. Trash		Green Waste		Clean Wood		Dirt, rocks (inerts)		C & D	
					cy	ton	cy	ton	cy	ton	cy	ton	cy	ton	cy	ton
SBWMA- Shoreway (current)	San Carlos	<input checked="" type="checkbox"/>		3000	\$35.00	\$84.00*	\$35.00	\$84.00*	\$25.00	\$70.00*	\$25.00	\$70.00*		\$83.00	\$28.00	
Shoreway proposed new rates	Proposed rate adjustments per adopted FY 09/10 budget				\$40.00	\$93.00*	\$40.00	\$93.00*	\$29.00	\$79.00*	\$29.00	\$79.00*		\$88.00	\$28.00	
Berkeley Transfer Station (rates effective 1/1/10)	Berkeley	<input checked="" type="checkbox"/>		560	\$29.00	\$126.00	\$29.00	\$126.00	\$23.00	\$67.00	\$23.00	\$67.00			\$29.00	\$126.00
Sunnyvale Smart Station	Sunnyvale	<input checked="" type="checkbox"/>		1500	\$16.00				\$13.00		\$17.50		\$69.50		\$32.50	
FERMA/SRDC	Redwood City		<input checked="" type="checkbox"/>	174 - C&D 499 - WW & GW					\$15.00		\$12.00		\$20.00		\$20.00	
Blue Line Transfer (South SF-Scavenger)	S. San Francisco		<input checked="" type="checkbox"/>	1200		\$88.00										
WM Davis Street TS (rates effective 10/1/10)	San Leandro		<input checked="" type="checkbox"/>	5600	\$30.62	\$121.43	\$30.62	\$121.43	\$26.00		\$26.00	\$60.00	\$55.00	\$105.00	\$30.62	\$121.43
Fremont Recycling & TS (BLT Enterprises) (rates effective 7/1/10)	Fremont		<input checked="" type="checkbox"/>	2400		\$81.72		\$81.72		\$80.32		\$80.32		\$80.32		\$80.32
Newby Island Landfill (Republic) (effective 7/1/09)	Milpitas		<input checked="" type="checkbox"/>	4000	\$37.00		\$37.00		\$29.00				\$30.00		\$33.00	
Ox Mountain Landfill (Republic) (effective 1/1/10)	Half Moon Bay		<input checked="" type="checkbox"/>		\$23.00	\$55.00	\$23.00	\$55.00	\$16.00	\$31.00	\$16.00	\$31.00	\$23.00	\$23.00	\$23.00	\$23.00
San Bruno Transfer Station (Recology)	San Bruno		<input checked="" type="checkbox"/>		\$50.00				\$50.00	\$65.00	\$50.00	\$65.00	\$65.00		\$40.00	\$65.00
SF Dump (Sunset Scavenger- Recology)	San Francisco		<input checked="" type="checkbox"/>	3000		\$140.76								\$140.76		\$140.76
Zanker Materials Recovery and Landfill	San Jose		<input checked="" type="checkbox"/>						\$12.00		\$8.00		\$25.00		\$25.00	

Note: *SBWMA member agency rate.

**SBWMA
SHOREWAY TRANSFER STATION OPERATIONAL EXPENSE DETAILS**

2011 Calendar Year Cost / Ton (Estimated):

	SBR Transfer Station fees	SBR Transfer Station Interim Ops Fees	SBR Transportation Fees	SBR Pass Through Costs ^a	SBWMA ^b	Allied Balancing Account ^c	SBWMA Debt Service	TOTAL
Material Type								
Solid Waste	\$ 10.39	\$ 0.78	\$ 13.77	\$ 1.43	\$ 11.75	\$ 4.67	\$ 1.89	\$ 44.68
Residential Organics	\$ 10.39	\$ 0.78	\$ 22.19	\$ 1.43	\$ 11.75	\$ 4.67	\$ 1.89	\$ 53.10
Commercial Organics	\$ 10.39	\$ 0.78	\$ 19.40	\$ 1.43	\$ 11.75	\$ 4.67	\$ 1.89	\$ 50.31
C&D	\$ 10.39	\$ 0.78	\$ 16.42	\$ 1.43	\$ 11.75	\$ 4.67	\$ 1.89	\$ 47.34

Notes: ^a Includes interest on capital expense, and one-time MRF project management expenses.
^b Includes SBWMA operating budget and non-operational Shoreway expenses.
^c Allied Waste balancing account pay-off for 2009-2010.

ASSUMPTIONS AND BACK-UP DETAIL

Shoreway Tons - 2011

TS	337,660	82.7%
MRF	70,559	17.3%
TOTAL TONS	408,219	100.0%

Masterplan Capital Cost Allocation

TS	21%
MRF	79%

SBR PASS-THROUGH COSTS

		% Alloc to TS			
Interest	\$ 308,120	82.7%	254,863	\$ 0.75	
Project Management	\$ 276,462	82.7%	228,677	\$ 0.68	<i>one-time cost</i>
TOTAL	\$ 584,582	82.7%	483,539	\$ 1.43	

SBWMA COSTS

		% Alloc to TS			
SBWMA Operating Budget	\$ 3,066,000	82.7%	2,536,054	\$ 7.51	
Insurance & Permits	\$ 200,000	82.7%	165,431	\$ 0.49	
Off Sight Parking (Hatcher Press)	\$ 60,000	82.7%	49,629	\$ 0.15	
Franchise Fees Paid to San Carlos	\$ 1,469,000	82.7%	1,215,089	\$ 3.60	
TOTAL	\$ 4,795,000	82.7%	3,966,204	\$ 11.75	

Debt Service, net of income	\$ 3,045,849	21.0%	639,628	\$ 1.89
------------------------------------	--------------	-------	---------	---------

ALLIED BALANCING ACCOUNT

2008	\$ 16,644			
2009	\$ 1,342,000			
2010 (3 months of payments in 2011)	\$ 218,000			
TOTAL	\$ 1,576,644	\$ 4.67		\$ 4.67



STAFF REPORT

To: SBWMA Board Members
From: Hilary Gans, Facility Operations Contract Manager
Date: November 18, 2010 Board of Director's Meeting
Subject: Resolution Approving BFI of California's Compost Overs Plan at the Newby Island Compost Facility for Processing of Organic Materials from the SBWMA.

Recommendation

It is recommended that the SBWMA Board of Directors approve Resolution No. 2010- 35 attached hereto authorizing the following action: Approval of BFI of California's Compost Overs Plan at the Newby Island Compost Facility for Processing of Organic Materials from the SBWMA.

Analysis

An agreement for Organics Materials Processing Services was signed with BFI Newby Island Compost facility in May 2010 that contained a "*Condition of Effectiveness of the Agreement*" which requires the Company to develop and implement a plan to divert "overs" from the landfill. While the SBWMA Board approved Newby Island as a processor for roughly one-half of the organic materials generated by the SBWMA, the effectiveness of the Agreement for Organic Materials Processing Services is subject to the SBWMA approving of the Company's plan for overs diversion on or before October 31, 2010.

Staff has met with the general manager of the BFI Newby Island Compost Facility on several occasions throughout 2010 to review progress in the development of a plan for processing the compost overs. Staff did not receive the Overs Processing Plan (see Exhibit A) from Newby Island Compost Facility until October 29, 2010 and so it was not possible to bring this item to the Board prior to the November 18th Board meeting. Staff has been able to verify that the screening system has been ordered, that it is scheduled for delivery in mid-December, and that the system will be dedicated to the processing of the compost overs (Newby has provided a PO# and system design). The screening system has been ordered from Bulk Handling Systems (BHS), Inc. in Eugene Oregon and is currently being manufactured.

Staff believes that this system will be state-of-the-art and will provide a high degree of material separation. Once processed and recovered by the screening system, the overs will be marketed to landscapers as a mulch or to Northern California biomass plants as a fuel product. Over the years as the sole processor for the SBWMA's organic materials, Newby has maintained an effective marking program for both landscape materials and for biomass fuel products. Staff believes that the company will be able to find non-landfill market outlets for the overs products. The System installation, system operations, and material marketing will continue to be monitored by Staff.

Background

Residential and commercial organic materials are currently collected and transferred at the Shoreway transfer station to the Newby Island Composting Facility. The current Shoreway Facility Operating Agreement with Republic Services (2005 Amended and Restated Facility Operating Agreement), includes the green and food materials composting services and is due to expire on December 31, 2010. In anticipation of this date and the SBWMA's ongoing need for organic materials processing services, the SBWMA issued a request for proposals (RFP) on April 2, 2008 for Organic Materials Processing Services.

The SBWMA Board approved Plant and Organic Materials Processing Agreements on April 22, 2010 with Grover Environmental Products (owned by Recology) and Newby Island Compost facility (owned by Republic Services) as its new compost services providers starting on January 1, 2011. Out of concern for Newby's continued use of compost overs (large woody materials screened from the organics materials after the compost process) as ADC at the Newby Island Landfill, the Board required that Newby implement an Overs Processing Plan to divert this material from the landfill. The BFI Agreement, unlike the Recology Grover Agreement, has a Condition of Effectiveness that states as follows: "Authority's approval through field certification or auditing of the Contractor's operational plan to ensure compost overs are put to beneficial use, exclusive of any use for alternative daily cover." The effective date of the Newby Organics Processing Services Agreement is October 31, 2010.

Fiscal Impact

None

Attachments:

Resolution 2010-35

Exhibit A - Newby Island Overs Processing Plan



RESOLUTION NO. 2010-35

RESOLUTION OF THE SOUTH BAYSIDE WASTE MANAGEMENT AUTHORITY BOARD OF DIRECTORS

WHEREAS, On April 22, 2010, the SBWMA Board of Directors approved Resolution No. 2010-13 directing staff to execute a Plant and Organic Materials Processing Agreement with Browning-Ferris Industries of California - Newby Island facility; and

WHEREAS, On May 3, 2010, the SBWMA and BFI of California executed the Agreement with the Agreement to become effective October 31, 2010 contingent upon the Authority's approval of a compost overs plan; and

WHEREAS, The BFI Newby Island Composting Operation has submitted a Compost Overs Processing Plan as attached in Exhibit A; and

WHEREAS, the plan relies on screening equipment and the company has demonstrated that it has purchased this screening equipment that will manufacture products from the overs materials.

NOW, THEREFORE BE IT RESOLVED that the South Bayside Waste Management Authority hereby approves BFI of California's Compost Overs Plan at the Newby Island Compost Facility for Processing of Organic Materials from the SBWMA.

PASSED AND ADOPTED by the Board of Directors of the South Bayside Waste Management Authority, County of San Mateo, State of California on the this 18th day of November, 2010, by the following vote:

Agency	Yes	No	Abstain	Absent	Agency	Yes	No	Abstain	Absent
Atherton					Menlo Park				
Belmont					Redwood City				
Burlingame					San Carlos				
East Palo Alto					San Mateo				
Foster City					County of San Mateo				
Hillsborough					West Bay Sanitary Dist				

I HEREBY CERTIFY that the foregoing Resolution No. 2010-35 was duly and regularly adopted at a regular meeting of the South Bayside Waste Management Authority on November 18, 2010.

ATTEST:

Jim Porter, Chairperson of SBWMA

Jeannene Minnix Kingston, Board Secretary



The Recyclery

October 29, 2010

Mr. Hilary Gans
South Bayside Waste Management Authority
610 Elm Street, Suite 202
San Carlos, CA 94070

Subject: Newby Island Overs Processing Plan

Dear Mr. Gans:

As you know, our new screening plant is in production and is scheduled for installation the week of December 6, 2010. The new equipment represents our best efforts to practically maximize the yield from our composting process, or rather, our best efforts to minimize the loss of organic material to residue.

I have attached a chart of the Newby Island Overs Processing Plan that represents the expected characterization of the compost process inputs/outputs by size from the new screening process. Further, I have included an outputs table that shows six separate product categories as well as applications for which the product categories will be suitable.

Products A through D will be marketed with the size characteristics shown while products E and F will represent combined products B/C/D (2" minus) and product C/D (1" minus) respectively. Each product has multiple potential applications that have been represented in the product applications table.

In addition to the equipment efforts, we have actively pursued new markets for our products as well expanding our offerings to our existing Customers. Further, we applied for and obtained the listing of our SHC (Super Humus Compost) with the OMRI (Organic Materials Review Institute) in **April 2010**.

OMRI's independent and transparent review of our materials and processes have generated interest and increased sales of our product in 2010 which will further enhance our marketing efforts going forward. We are very encouraged by the responses we are receiving in market.

We are very excited about our new overs processing plan and the new market opportunities it will make possible. I want to again extend my personal invitation for you to observe/participate in the "start-up" and testing of this new equipment.

Please contact me with any questions you.

Regards,

A handwritten signature in blue ink that reads 'Mark Buntjer'.

Mark Buntjer
General Manager

1601 Dixon Landing Road • Milpitas, CA 95035 • Phone (408) 262-1401 • Fax (408) 262-0603

Newby Island Compost Overs Processing Plan

Newby Island: Raw Compost						
Equipment Used: Dual Deck 9 Shaft DRS - 2" IFO						
	Input Material		Unders		Overs	
Material	Weight	Comp%	Weight	Comp%	Weight	Comp%
Input	100	100%				
2" -			86	85.9%		
2"+					14	14.1%

Newby Island: 2" Unders						
Equipment Used: Single Deck 21 Shaft DRS - 1" IFO						
	Input Material		Unders		Overs	
Material	Weight	Comp%	Weight	Comp%	Weight	Comp%
Input	86	100%				
1" -			73	85.2%		
1" +					13	14.8%

Newby Island: 2" Overs								
Equipment Used: SDS-500 Drum Separator w/Lights Conveyor Aspirator								
	Input Material		Heavy / Unders		Light / Overs		Aspirated Film	
Material	Weight	Comp%	Weight	Comp%	Weight	Comp%	Weight	Comp%
Input	14.1							
Final wt.	12.1	100%						
LOST	2.0							
Heavies			5	42.9%				
Lights					7	54.3%		
Film/Dust							0	2.8%

73.2%
12.7%

2.0%
5.2%
6.6%
0.3%

Newby Island: 1" Unders						
Equipment Used: 3/8" Trommel						
	Input Material		Unders		Overs	
Material	Weight	Comp%	Weight	Comp%	Weight	Comp%
Input	73	100%				
3/8" -			66	89.9%		
3/8" +					7	10.1%

65.8%
7.4%

Newby Island: Aspirated Lights									
Equipment Used: 3/8" Trommel with Airlifter									
	Input Material		Unders		Overs		Aspirated Film		
Material	Weight	Comp%	Weight	Comp%	Weight	Comp%	Weight	Comp%	
Input	7	100%							
3/8" -			1	18.9%					
3/8" +					5.14	78%			
							0	3.0%	

1.2%
5.1%
0.2%

OUTPUTS TABLE					
PRODUCT	SIZE	TONS	PRODUCT E	PRODUCT F	
A	2"+	5			5.2%
B	<2" >1"	13			12.7%
C	<3/8"	67	87.1%	79.7%	67.0%
D	>3/8" <1"	7			7.4%
Residue	Misc.	5			5.1%
Residue	Plastic Film	1			0.5%
Unaccounted For		2			2.0%
		100			100.0%

5.7%

PRODUCT APPLICATIONS						
	Product A	Product E	Product B	Product F	Product D	Product C
Application	2" Plus	2" Minus	2" / 1"	1" Minus	1" / 3/8"	3/8" Minus
Biofuel	X		X			
Landscape Mulch	X	X	X	X	X	X
Erosion Control	X	X	X	X	X	X
Sediment Berm		X		X	X	X
Soil Amendment	X	X	X	X	X	X
Turf Topdressing						X
Growing Media				X	X	X
Agriculture	X	X	X	X	X	X

EQUIPMENT LIST

ITEM NUMBER	DESCRIPTION	MODEL NUMBER
	PRIMARY SCREEN PACKAGE	
001	FEED HOPPER	
002	FEED CONVEYOR VARIABLE SPEED-cleatlok belt	IC60
003	FEED CONVEYOR SUPPORT SKID	
004	BHS DEBRIS ROLL SCREEN®	DRS72 9-9
005	PRIMARY SCREEN UNDERS CHUTE	
006	PRIMAY SCREEN UNDERS CONVEYOR	IC42
007	PRIMARY SCREEN OVERS CONVEYOR	LPS48
008	PRIMARY SCREEN SUPPORT SKID	
009	SYSTEM CONTROL PANEL NEMA 4	
	FILM SEPARATION PACKAGE	
010	FILM ASPIRATOR	AS10-60X18
011	COMBISEPARATOR 96-126 WITH AIRLOCK	
012	EXHAUST FAN	20HP
013	FAN DISCHARGE DUCT 16"	
014	COMBISEPARATOR SUPPORT SKID WITH CONCRETE BALLAST 2CY	
	FINES SCREEN PACKAGE	
015	BHS DEBRIS ROLL SCREEN®	DRS50-21
016	FINES SCREEN UNDERS CHUTE	
017	FINES SCREEN UNDERS CONVEYOR	IC42
018	FINES SCREEN OVERS CONVEYOR	LPS30
019	FINES SCREEN SUPPORT SKID	

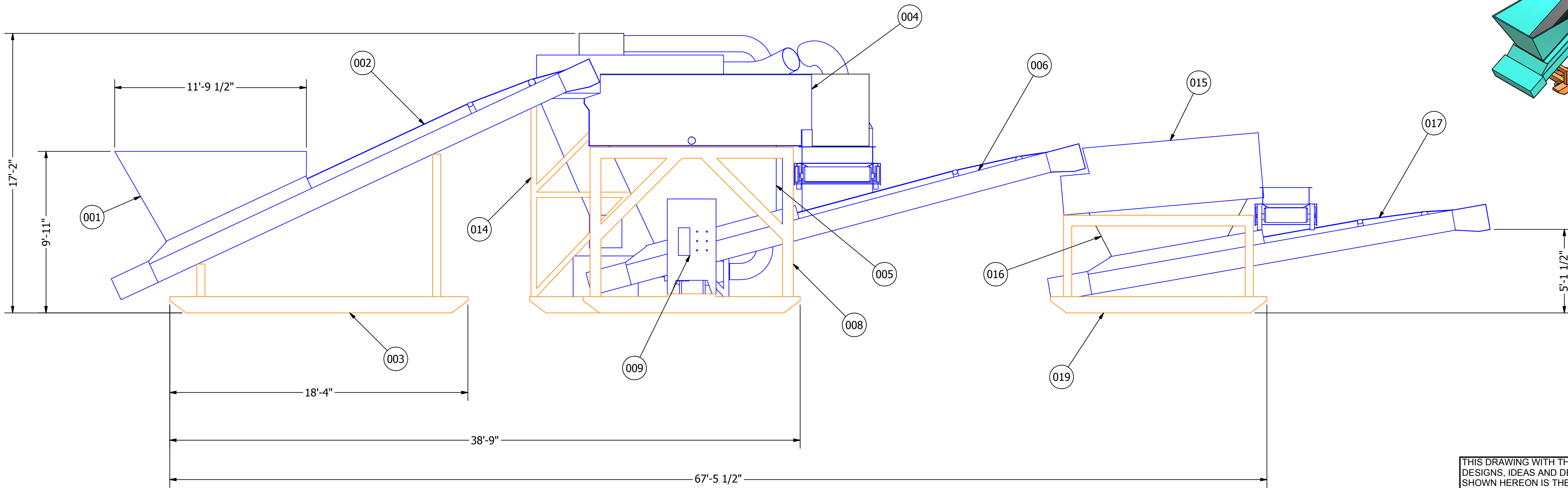
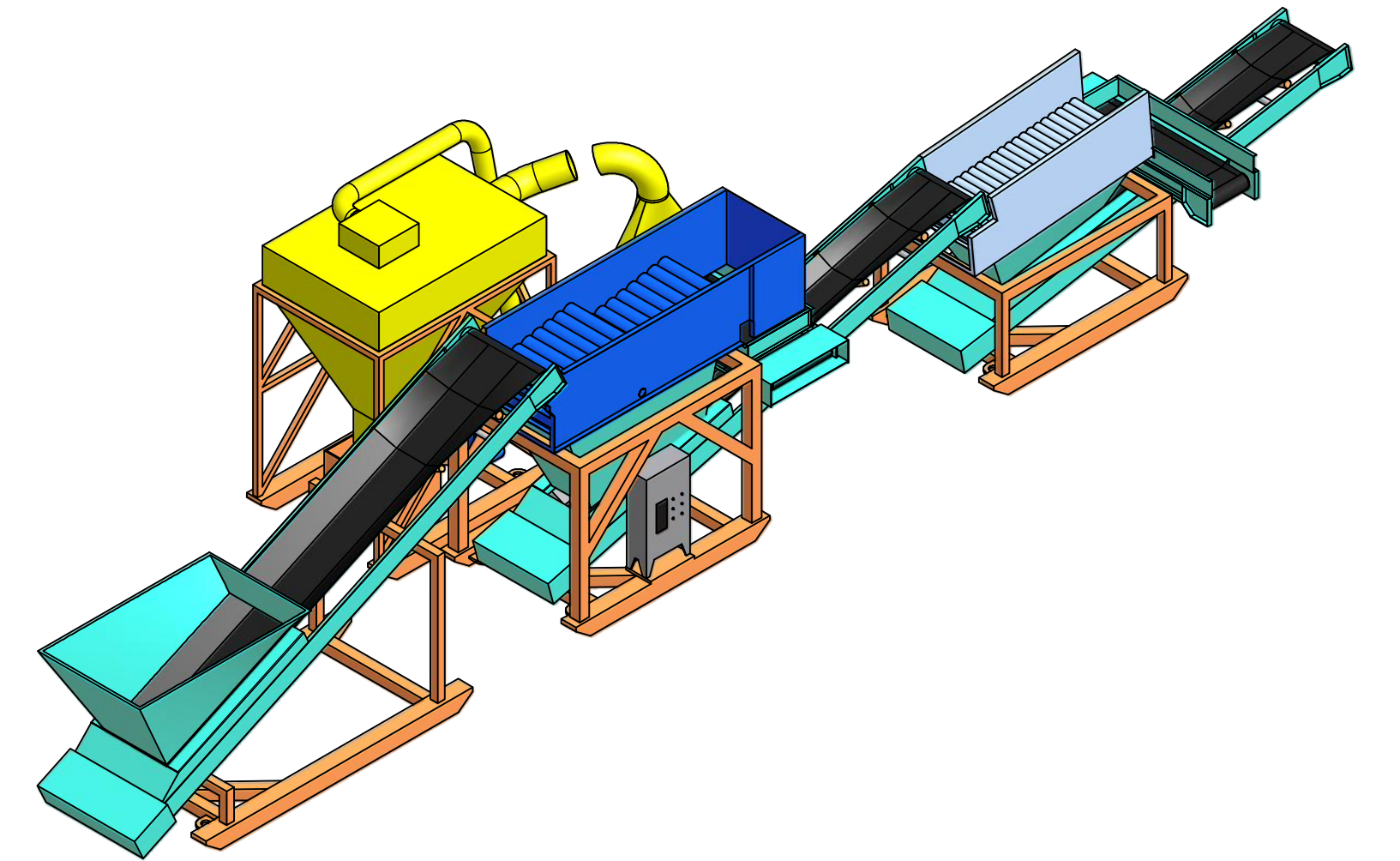
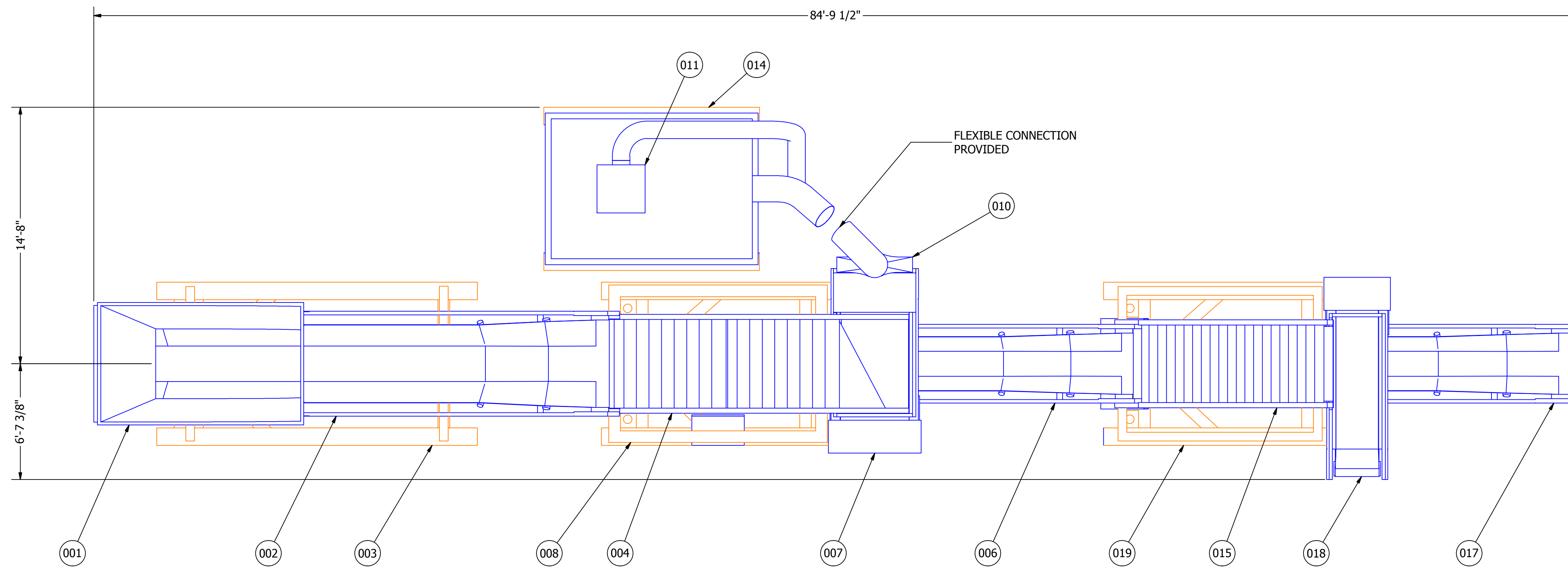

THIS DRAWING WITH THE DESIGNS, IDEAS AND DETAILS SHOWN HEREON IS THE PROPERTY OF: BULK HANDLING SYSTEMS, EUGENE OREGON AND IS TO BE RETURNED UPON REQUEST.

IT SHALL NOT BE USED, DISCLOSED TO OTHERS, OR COPIED IN WHOLE OR PART WITHOUT WRITTEN PERMISSION.

FILE: 7887-020A1D ASSEMBLY

1 REV	REFERENCE ONLY DESCRIPTION	RRM DRN	4/6/2010 DATE
BULK HANDLING SYSTEMS		1040 ARROWSMITH EUGENE, OR 97402 PHONE: (541) 485-0999 FAX: (541) 485-6341	
CLIENT: REPUBLIC SERVICES, IN. LOC: MILPITAS, CALIFORNIA (NEWBY ISLAND)		JOB#	P-7887
TITLE: SEMI-PORTABLE COMPOST SCREENING PLANT		DWG#	7887-2.0
DATE: 4/6/2010		SHEET	1 OF 2
		SCALE:	1



STAFF REPORT

To: SBWMA Board Members
From: Cliff Feldman, Recycling Programs Manager
Date: November 18, 2010 Board of Director's Meeting
Subject: Resolution Approving SBWMA Consent to Assignment of the Agreement Between SBWMA and Curbside Inc. for Household Hazardous Waste (HHW), Universal Waste (U-Waste), Electronic Scrap (E-Scrap), Sharps and Medicine Door-to-Door Collection, Recycling and Disposal Service to WM Curbside LLC.

Recommendation

It is recommended that the SBWMA Board of Directors approve Resolution No. 2010-36 attached hereto authorizing the following action:

1. Consent and approve the assignment of the Agreement between SBWMA and Curbside Inc. for household hazardous waste, universal waste, electronic scrap, medicine and sharps door-to-door collection, recycling and disposal service to WM Curbside LLC, contingent on execution of Amendment Number 1 to this Agreement attached hereto as Exhibit A.
2. Authorize staff to execute Amendment Number 1 to the Agreement with Curbside Inc. extending the contract for two years through December 31, 2014 and providing the SBWMA the option to further extend the contract for up to two consecutive one year terms.

Analysis

In October 2010, the President of Curbside Inc., Mr. William Anderson, notified the SBWMA that the company had negotiated an agreement to be purchased by Waste Management Inc. and the new company would be called WM Curbside LLC. The transaction is scheduled to close by the end of November 2010. Mr. Anderson has provided assurance that the management and all other employees would not change and the program would continue to be operated as it is currently operated.

The Agreement between the SBWMA and Curbside Inc. to provide Household Hazardous Waste (HHW), Universal Waste (U-Waste), Electronic Scrap (E-Scrap), Sharps and Medicine Door-to-Door Collection Service contains the following provision related to assignment of this contract:

"Contractor shall not assign any of its rights nor transfer any of its obligations under the Agreement without the prior written consent of the Authority."

As a condition of the SBWMA authorizing assignment of the Agreement, staff negotiated an extension of the current contract. The current Agreement was for three years with an expiration date of December 31, 2012. The extension provides an additional two years through December 31, 2014 and also provides SBWMA the option to proceed with up to two one year extensions.

Extension of the current agreement with Curbside Inc. is favorable to the SBWMA to ensure that the program will be continued without interruption as is for two and perhaps four more years. In addition, extending the current contract is also a good idea for the SBWMA since it locks in the current terms and conditions, notably the most favored customer provision and annual price increases that are limited to a consumer price index.

Background

On February 26, 2009 the SBWMA Board of Director's authorized staff to negotiate a contract with Curbside Inc. to provide door-to-door collection service of Household Hazardous Waste, Universal Waste, E-Scrap and Sharps on behalf of Member Agencies that expressed an interest by April 2, 2009. Initially, seven Member Agencies expressed an interest to participate.

On June 25, 2009, the SBWMA Board of Director's approved the SBWMA FY 09/10 Operating Budget which included an allocation of \$125,000 to design and roll-out a public education campaign for the Member Agencies that expressed an interest in participating in this program.

On October 22, 2009, the SBWMA Board of Director's directed staff to execute a three year Agreement with Curbside Inc. and this contract was executed on November 12, 2009.

The program was rolled out in 2010 and the following seven Member Agencies are currently participating:

- Belmont
- Hillsborough
- Menlo Park
- San Carlos
- City of San Mateo
- West Bay Sanitary District
- East Palo Alto

Fiscal Impact

There is no fiscal impact associated with the recommendation.

Attachments:

Resolution 2010- 36

Exhibit A - Amendment Number 1 to the Agreement with Curbside Inc.



RESOLUTION NO. 2010-36

RESOLUTION OF THE SOUTH BAYSIDE WASTE MANAGEMENT AUTHORITY BOARD OF DIRECTORS AUTHORIZING ASSIGNMENT OF THE AGREEMENT BETWEEN THE SBWMA AND CURBSIDE INC. TO WM CURBSIDE LLC . AND EXTENDING THE AGREEMENT FOR TWO YEARS WITH TWO ONE YEAR OPTIONS

WHEREAS, The Authority is a joint powers agency organized under the Joint Exercise of Powers Act by cities and other local government agencies in San Mateo County (the "Member Agencies"), each of which oversees the collection of solid waste, plant materials and recyclable materials within its jurisdiction; and

WHEREAS, On October 22, 2009, the SBWMA Board of Directors approved Resolution No. 2009-31 directing staff to execute a three year agreement with Curbside Inc. to provide household hazardous waste, universal waste, electronic scrap, medicine and sharps door-to-door collection, recycling and disposal service; and

WHEREAS, On November 12, 2009, the SBWMA and Curbside Inc. executed an agreement with a term of January 1, 2010 through December 31, 2012; and

WHEREAS, On June 26, 2009, the SBWMA Board of Director's approved the SBWMA FY 09/10 Operating Budget which included \$125,000 to develop and roll-out a public education campaign for the seven member agencies that had expressed an interest to participate; and

WHEREAS, Curbside Inc. is requesting authorization from the SBWMA that its agreement with the SBWMA be assigned to WM Curbside LLC, which will be a wholly owned subsidiary of Waste Management Inc.; and

WHEREAS, Waste Management Inc. is a reputable company in the solid and hazardous waste disposal and recycling industry with operations similar to those included in the contract between the SBWMA and Curbside Inc. and is therefore an acceptable company for assignment of the Curbside Inc. agreement.

NOW, THEREFORE BE IT RESOLVED that the South Bayside Waste Management Authority hereby:

1. Considers Waste Management Inc. to be an acceptable company for assignment of the SBWMA Agreement with Curbside Inc. for household hazardous waste, universal waste, electronic scrap, medicine and sharps door-to-door collection, recycling and disposal service.
2. Consents and approves the assignment of the Agreement between SBWMA and Curbside Inc. to provide household hazardous waste, universal waste, electronic scrap, medicine and sharps door-to-door collection, disposal and recycling service to WM Curbside LLC contingent on execution of Amendment Number 1 to this Agreement attached hereto as Exhibit A.

3. Authorizes staff to execute Amendment Number 1 to the Agreement with Curbside Inc. extending the contract for two years through December 31, 2014 and providing the SBWMA the option to further extend the contract for up to two consecutive one year terms.

PASSED AND ADOPTED by the Board of Directors of the South Bayside Waste Management Authority, County of San Mateo, State of California on the this 18th day of November, 2010, by the following vote:

Agency	Yes	No	Abstain	Absent	Agency	Yes	No	Abstain	Absent
Atherton					Menlo Park				
Belmont					Redwood City				
Burlingame					San Carlos				
East Palo Alto					San Mateo				
Foster City					County of San Mateo				
Hillsborough					West Bay Sanitary Dist				

I HEREBY CERTIFY that the foregoing Resolution No. 2010-36 was duly and regularly adopted at a regular meeting of the South Bayside Waste Management Authority on November 18, 2010.

ATTEST:

Jim Porter, Chairperson of SBWMA

Jeannene Minnix Kingston, Board Secretary

**AMENDMENT NUMBER 1 TO THE
AGREEMENT WITH CURBSIDE INC. TO PROVIDE HOUSEHOLD HAZARDOUS
WASTE, UNIVERSAL WASTE, ELECTRONIC SCRAP, SHARPS AND MEDICINE
DOOR-TO-DOOR COLLECTION, RECYCLING AND DISPOSAL SERVICES**

THE AGREEMENT to provide Household Hazardous Waste, Universal Waste, Electronic Scrap, Sharps and Medicine Door-to-Door Collection, Recycling and Disposal Services executed on the 11th day of November 2009, by and between the South Bayside Waste Management Authority (“Authority”) and Curbside, Inc., a California Corporation (“Contractor”) is hereby amended as specified below.

WHEREAS, the Authority desires to continue utilizing the services of Contractor to establish and manage the Authority’s Household Hazardous Waste, Universal Waste, E-Scrap and Sharps Door-to-Door Collection, Recycling and Disposal Program (“Program”); and

WHEREAS, Contractor is qualified, ready, willing and able to furnish such services.

WHEREAS, Contractor intends to assign its Agreement to WM Curbside LLC and execution of this Amendment Number 1 is a requirement of Authority to authorizing consent to assign this Agreement.

NOW, THEREFORE, THE PARTIES AGREE TO AMEND THE AGREEMENT BY REPLACING IN ITS ENTIRETY SECTION 3, AS FOLLOWS:

3. TERM AND SCHEDULE

The Term shall begin on January 1, 2010 and shall continue until December 31, 2014, unless earlier terminated. Contractor shall begin providing service to any Authority member agency within thirty (30) days of authorization by the Authority.

Upon the expiration of the Term, the parties may agree to extend this Agreement on a mutually satisfactory term or the Authority can extend this Agreement at its sole discretion for up to two (2) additional years, in one (1) year increments, upon providing Contractor thirty (30) days written notice.

IN WITNESS WHEREOF, the parties hereto have executed this Amendment Number 1 by their duly authorized representatives as of the day and year first above written.

Authority:

SOUTH BAYSIDE WASTE
MANAGEMENT AUTHORITY

By: _____
Name: Kevin McCarthy
Title: Executive Director

Contractor:

CURBSIDE, INC.

By: _____
Name: William Anderson
Title: President

By: _____
Name: _____
Title: Secretary